Back Extension

Owner's Manual



LifeFitness

Back Extension

1. Assembly Instructions

Item	Description	Qty	Part Number
1	Front Foot	1	78770XX
2	Center Frame	1	78761XX
3	M10 x 135mm Bolt	2	3256221
4	Flat Washer	10	3102514
5	Nylock Nut	2	3242002
6	Waist Frame	1	78768XX
7	M10 x 25mm Bolt	10	3256202
8	Spacer	2	7385203
9	Hole Plug	1	3237403
10	Roller Pad	2	7424701
11	Plate	2	7322301
12	Bearing Cap	2	7308701
13	Angle Pad	2	7877101
14	Gas Spring	1	3235702

Tools Required:

- 7mm Allen Wrench
- 17mm Wrench
- Ratchet
- 3" Ratchet Extension
- 17mm Socket
- 7mm Hex Bit

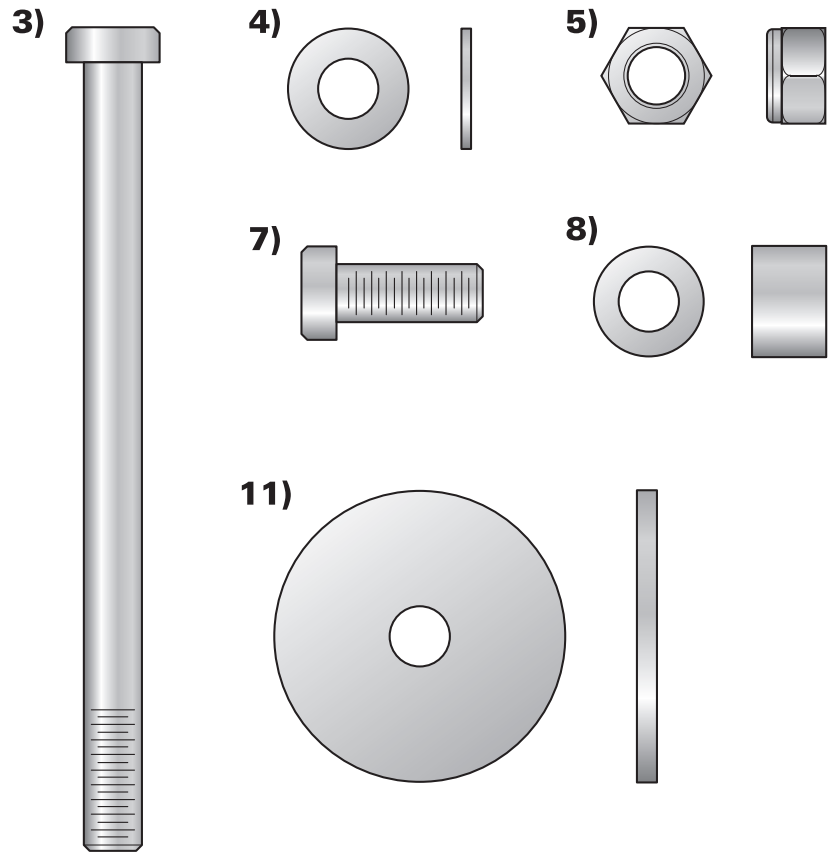

1. Attach the FRONT FOOT (1) to the CENTER FRAME (2) using two M10 x 135mm BOLTS (3), FLAT WASHERS (4), and NYLOCK NUTS (5). Tighten the BOLTS and NUTS securely.

2. With the WAIST FRAME (6) positioned as shown, carefully slide the WAIST FRAME into the CENTER FRAME (2). Pull the POSITIONING PIN (A) upward to allow the WAIST FRAME to slide past. Release the POSITIONING PIN and allow the pin to engage the WAIST FRAME.

Slide the GLIDE CAP (B) downward and into the top of the CENTER FRAME (2). Secure the GLIDE CAP using two M10 x 25mm BOLTS (7) and SPACERS (8). Tighten the BOLTS securely.

Insert the SMALL HOLE PLUG (9) into the access hole located opposite the POSITIONING PIN (A)

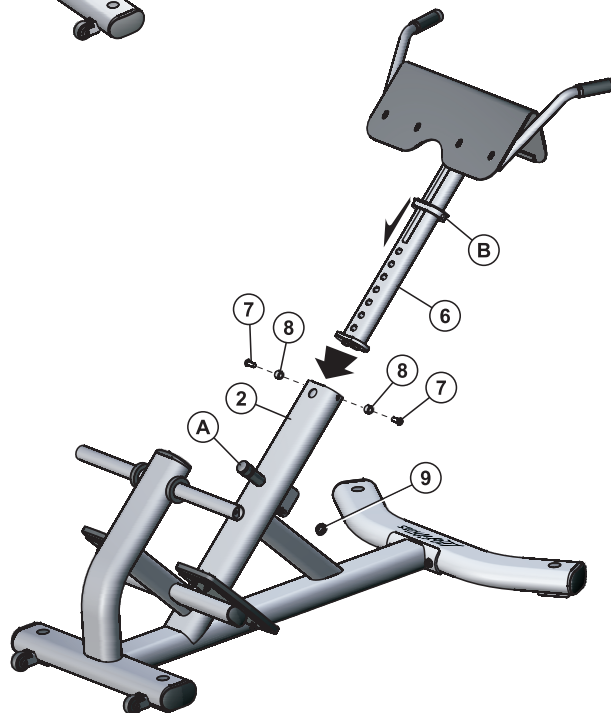
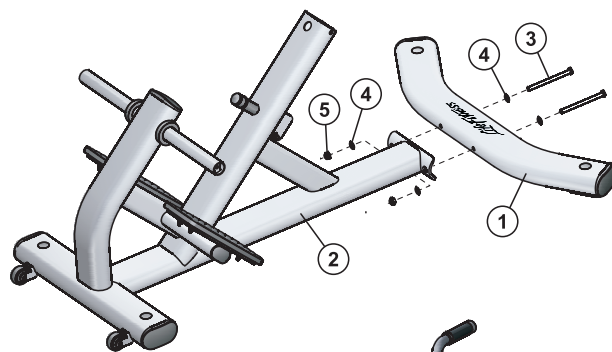

Back Extension

1. Assembly Instructions

3. Attach one ROLLER PAD (10) to a CENTER FRAME SHAFT (C) using ONE PLATE (11), M10 x 25mm BOLTS (7) and BEARING CAP (12). Tighten the BOLTS securely.

Repeat for the remaining ROLLER PAD (10).

4. Attach the ANGLE PADS (13) to the WAIST FRAME (6) as shown using six M10 x 25mm BOLTS (7) and FLAT WASHERS (4). Tighten the BOLTS securely.

5. Snap the GAS SPRING (14) to the CENTER FRAME (2) and WAIST FRAME (6) as shown.

Be sure the GAS SPRING snaps securely to the mounting posts.

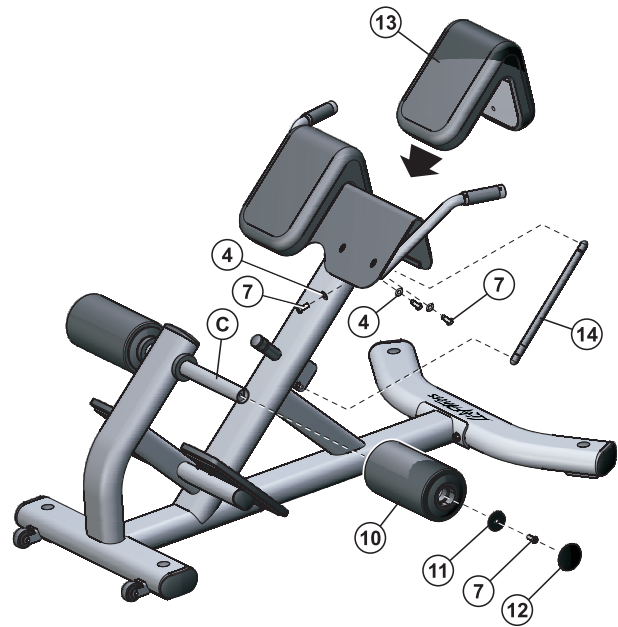

Back Extension

2. Safety & Warranty

It is the sole responsibility of the purchaser of Life Fitness products to instruct all individuals, whether they are the end user or supervising personnel on proper usage of the equipment.

It is recommended that all users of Life Fitness exercise equipment be informed of the following information prior to its use.

PROPER USAGE

1. Do not use any equipment in any way other than designed or intended by the manufacturer. It is imperative that all Life Fitness equipment is used properly to avoid injury.
2. Keep hands and feet clear at all times from moving parts to avoid injury.
3. It is the purchaser's sole responsibility to properly instruct end users and supervising personnel as to the proper operating procedures of all Life Fitness equipment.

CHECK FOR DAMAGED PARTS

1. DO NOT use any equipment that is damaged and or has worn or broken parts. Use only replacement parts supplied by Life Fitness.
2. MAINTAIN LABELS AND NAMEPLATES. Do not remove labels for any reason. They contain important information. If unreadable or missing, contact LIFE FITNESS for a replacement.
3. SECURE EQUIPMENT. All equipment MUST be secured to the floor to stabilize and eliminate rocking or tipping over. This must be performed by a licensed contractor.
4. Ensure that any person(s) making adjustments or performing maintenance or repair of any kind is qualified to do so. Life Fitness will provide service and maintenance training at our corporate facility upon request or in the field if appropriate arrangements are made.

SPECIFIC OPERATING WARNINGS

1. Do not allow users to wear loose fitting clothing while using equipment. It is also recommended to have users secure long hair back and up to avoid contact with moving parts.
2. It is the purchaser's sole responsibility to properly instruct end users and supervising personnel as to the proper operating procedures of all Life Fitness equipment.
3. Keep children away from strength equipment. Parent or others supervising children must provide close supervision of children if the equipment is used in the presence of children.
4. UNDERSTANDING EACH AND EVERY WARNING TO THE FULLEST EXTENT IS IMPORTANT. IF ANY OF THESE WARNINGS ARE UNCLEAR, ASK FOR CLARIFICATION FROM LIFE FITNESS PERSONNEL.
5. It is recommended that all individuals consult a physician prior to commencing an exercise program. If at any time during exercise a exerciser feels faint, dizzy or experience pain, he/she should stop and consult a physician.

Back Extension

2. Safety & Warranty

WARRANTY

WHAT IS COVERED

This Life Fitness commercial exercise equipment (Back Extension) is warranted to be free of all defects in material and workmanship.

WHO IS COVERED

The manufacturer's warranty covers the original purchaser or any person receiving the Product as a gift from the original purchaser.

WHO PAYS TRANSPORTATION & INSURANCE FOR SERVICE

If the Product or any covered part must be returned to a service facility for repairs, Life Fitness, will pay all transportation and insurance charges for the first year. The purchaser is responsible for transportation and insurance charges during the second and third years (if applicable).

WHAT WE WILL DO TO CORRECT COVERED DEFECTS

Life Fitness will ship any new or rebuilt replacement parts or components, or, at the option of Life Fitness, replace the Product. Such replacement parts are warranted for the remaining portion of the original warranty period.

WHAT IS NOT COVERED

Any failures or damage caused by unauthorized service, misuse, accident, negligence, improper assembly or installation, debris resulting from any construction activities in the Product's environment, rust or corrosion as a result of the Product's location, alterations or modifications without our written authorization or by failure on the purchaser's part to use, operate and maintain the Product as set out in your Owner's Manual (.Manual.). All terms of this warranty are void if this Product is moved beyond the continental borders of the United States of America (excluding Alaska, Hawaii and Canada) and are then subject to the terms provided by that country's local authorized Life Fitness representative.

OWNER'S MANUAL

It is VERY IMPORTANT THAT YOU READ THIS MANUAL before operating the Product. Remember to perform the periodic maintenance specified in the Manual to assure proper operation and continued satisfaction with the Product.

HOW TO GET PARTS & SERVICE

Call Customer Support Services at (800) 351-3737 or (847) 451-0036, Monday through Friday from 8:00 a.m. to 6:00 p.m. Central Standard Time. Have the following information available when calling; name, address and serial number of the Product. Life Fitness will provide information on how to obtain a replacement part, advice on how and where to ship the Product for service or, if necessary, arrange for on-site service.

Before shipping the Product:

1. Obtain a Return Authorization Number (RA#) from Customer Support Services
2. Securely pack your Product (use the original shipping carton, if possible)
3. Write the RA# on the outside of the carton
4. Insure the Product, and
5. Include a letter explaining the defect or problem and a copy of the proof of purchase if you believe the service is covered by warranty.

EXCLUSIVE WARRANTY

THIS LIMITED WARRANTY IS IN LIEU OF ALL OTHER WARRANTIES OF ANY KIND EITHER EXPRESSED OR IMPLIED, INCLUDING BUT NOT LIMITED TO THE IMPLIED WARRANTIES OF MERCHANTABILITY AND FITNESS FOR A PARTICULAR PURPOSE, AND ALL OTHER OBLIGATIONS OR LIABILITIES ON THE PART OF LIFE FITNESS. Life Fitness neither assumes nor authorizes any person to assure for Life Fitness any other obligation or liability concerning the sale of this Product. Under no circumstances shall Life Fitness be liable under this warranty, or otherwise, of any damage to any person or property, including any lost profits or lost savings, for any special, indirect, secondary, incidental or consequential damages of any nature arising out of the use of or inability to use this Product. Some states do not allow the exclusion or limitation of implied warranties or of liability for incidental or consequential damages, so the above limitations or exclusions may not apply in those instances.

CHANGES IN WARRANTY NOT AUTHORIZED

No one is authorized to change, modify or extend the terms of this limited warranty.

EFFECT OF STATE LAWS

This warranty gives you specific legal rights and you may have other rights, which vary, from state to state.

THE LIFE FITNESS PLEDGE TO YOU

Life Fitness Products are designed and manufactured to the highest standards.

Life Fitness wants its customers to be completely satisfied with the its Product and will do everything possible under the terms of this warranty to keep its customers secure in knowing they have bought the best!

Back Extension

3. Specifications

General Specifications

1. Frame Construction

Frame is constructed of mechanical quality steel purchased in mill run quantities.
Frame is primarily 2 ½" x 4 ½" oval-shaped tubing with 11 gauge wall thickness.

2. Frame Finish

Prior to applying finish, each part is chemically washed to prepare surface for maximum adhesion.

3. Upholstery

Contoured pads.
All edges are stitched to eliminate any folds in the material that would limit durability.

4. Foam

Three and four pound EVA foam (deformation resistant) or equivalent is used on all machines. The foam is injection molded directly to the multi-wood support board with integral 10mm T-nuts.

5. Hand Grips

Hand grips are an extruded 60-durometer-thermorubber compound that is non-absorbing, wear and tear resistant, and exhibits good dry and wet frictional characteristics.
The grips are retained with aluminum collars, which eliminate the tendency of the grips to slide off the handle.

6. Foot Platforms

Foot platforms are molded rubber with a slip resistant texture.

7. Equipment Anchoring

All machines have holes in the feet, which allow for easy anchoring to the floor. Life Fitness recommends that all machines be anchored to the floor to minimize the possibility of tipping.

8. Warranty

10-year minimum warranty on frames, 5 years on integral bearings, 1 year on grips, and 90 days on upholstery and any items not specified.

9. Liability Insurance

Certificate of insurance available upon request.

Product Specifications

Body Weight Back Extension	Product # - SBWBE	
Machine Weight:	140 lbs.	63,5 kg.
Size:	in = 54 L x 37 W x 37 H	cm = 137 L x 94 W x 94 H

- Adjustable pad support to accommodate users of all sizes.
- V-shaped pad design provides greater comfort throughout range of motion.
- Lower roller pads positioned to increase stabilization and comfort throughout the exercise.
- Handles positioned for easy entry and exit without interfering with the exercise.
- Wheels for easy transportation.

Back Extension

4. Maintenance

ONCE A DAY

- Wipe down upholstery with a mild soap and water or comparable all purpose cleaner.

ONCE A WEEK

- Visually inspect all hardware for loosening, tampering or wear.
- Check condition of hand grips.

ONCE A MONTH

- Inspect hardware and tighten any bolts or nuts that may have loosened during use.

ACTION	DAILY	MONTHLY	BI-ANNUALLY	AS NEEDED
CLEAN				
Upholstery	X			
Hand Grips				X
INSPECT				
Hardware		X		
Frame			X	
Hand Grips				X

CLEAN

- Upholstery with a mild soap and water.
- Hand grips with mild soap and water.

INSPECT

- Hardware should be checked for looseness. Tighten as required using metric tools.
- Frames should be inspected for wear or damage.
- Hand grips should be checked for wear or damage.

NOTE: Use polishing compound (such as car wax) to clean and remove shoe scuffs from frame surfaces as necessary.

© 2005 Life Fitness, a division of Brunswick Corporation. All rights reserved.
Life Fitness is a registered trademark of Brunswick Corporation.

8006201 REV. A 10-28-05

LifeFitness